

# CURRENT PRODUCTS model:CSP350

## SUPER MIX24

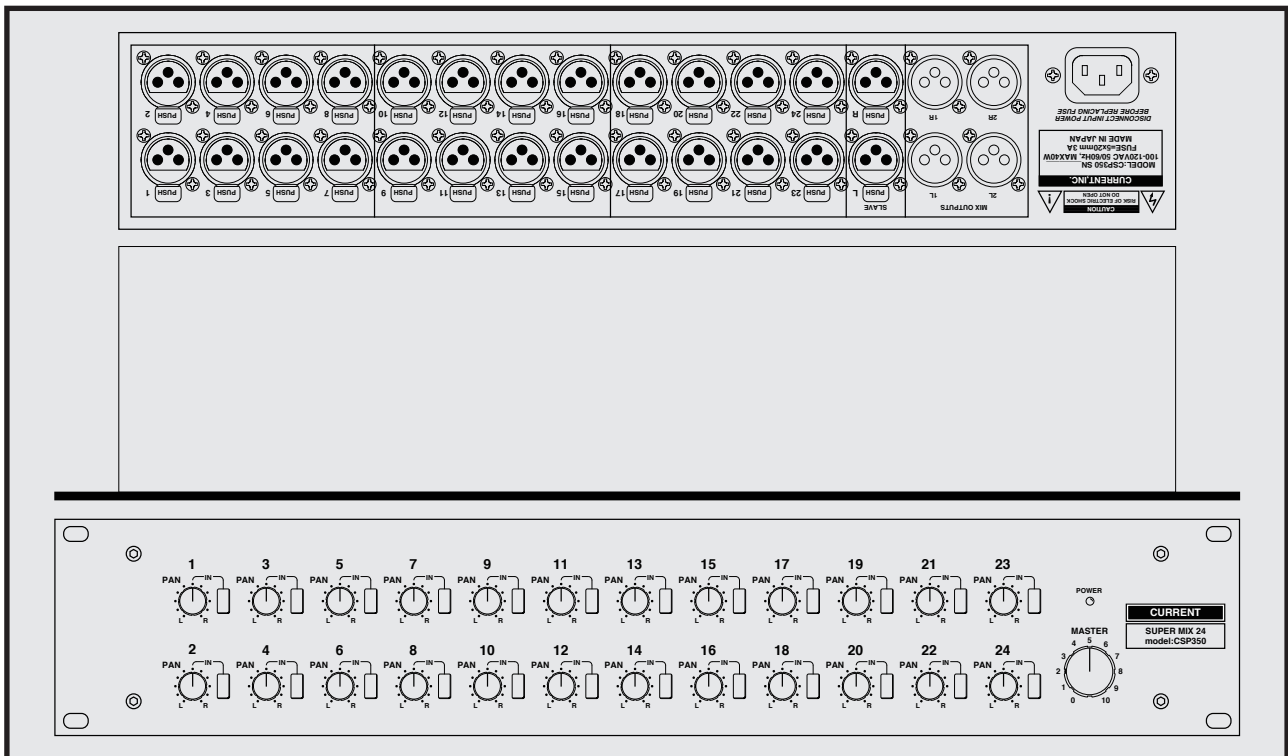

It is most suitable for mix of DAW  
 24ch input  
 Cascade connection possibility  
 ON/OFF of PAN  
 The master volume  
 Super high-quality sound  
 19 inches 2U size

**CSP350 is a unit to mix source of 24ch precisely. In DAW such as ProTools, the other side that assigned PAN is the same as the state that lowered the fader and becomes rough digitally, and a tone of the left and right is different. Even if the side that assigned PAN is 24 bits, in the other side, 8 bits is in condition that there is not it. It solves this problem in CSP350 by mixing it in analog.**

### "PAN"

Only the channel which turned on PAN button is output via panpot and is output MONO without going via panpot in the case of OFF. Moreover, there is not the center click to allow is fine, panning in panpot. In addition, the center level of PAN is -3dB.

### "Cascade"

It implements SLAVE input to mix a cascade connection and external source of multiple CSP350. SLAVE input is circuit configuration to insert to a mix bus. It can regard this as input of 25 and the 26th without the level control.

### "Output"

It is output 2 with an independent buffer amplifier and can use it for a monitor and records.

### "Mix level"

For the possibility that a mix amplifier clips depending on input source, the mix gain at the standard is set in -6dB. The element for gain setting is implemented by a socket and can change in 0dB and -10dB.

### "Others"

Please consider in addition in CSP349 of the monitoring system. There are CSP162, CSP340 in the mix unit of 8ch of the others. In addition, please refer about kahan rack, the connection cable.



### SPECIFICATIONS

- 🍏 **AUDIO INPUTS:** BALANCED, 24kΩ
- 🍏 **CONNECTOR:** XLR3-F
- 🍏 **INPUTS REFERENCE LEVEL:** +4dBu, MAX=+24dBu
- 🍏 **AUDIO OUTPUTS:** BALANCED, 50Ω
- 🍏 **CONNECTOR:** XLR3-M
- 🍏 **OUTPUTS REFERENCE LEVEL:** +4dBu, MAX=+24dBu
- 🍏 **FREQ.RESPONSE:** 20 to 20kHz ±0.1dB
- 🍏 **THD:** <0.01% at Ref.Level
- 🍏 **EIN:** <-90dB
- 🍏 **MAINS:** 100VAC 50/60Hz MAX 40W
- 🍏 **DIMENSIONS:** 482Wx88Hx303D, 6kg

Super mix 24      CSP350      ¥480,000

accessory : AC cable

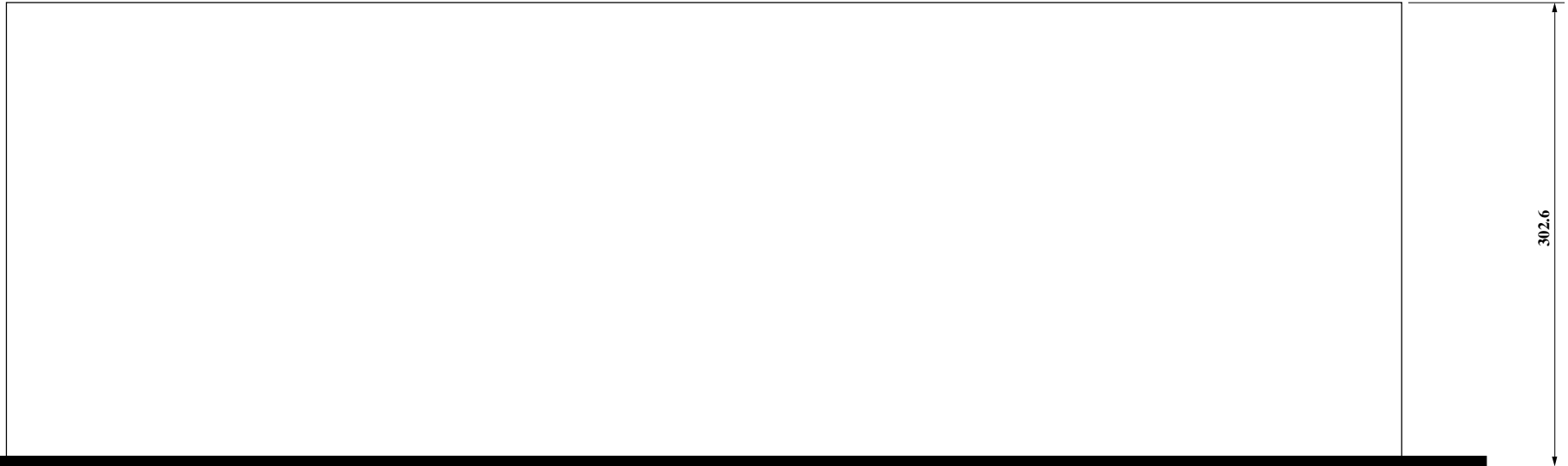
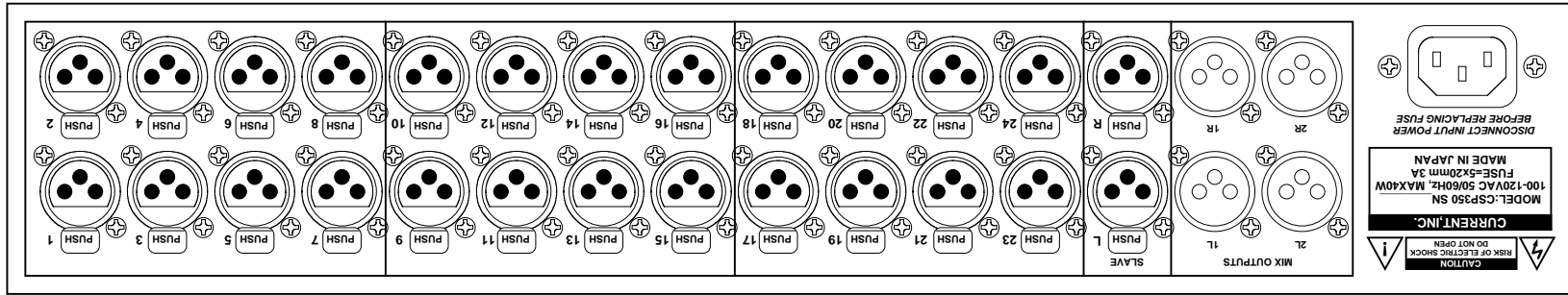

302.6

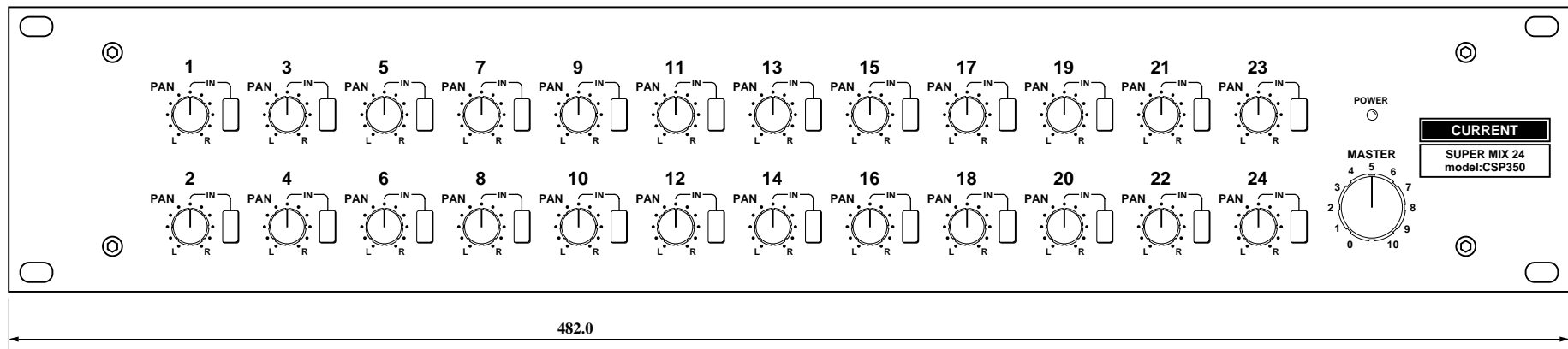

88.0

482.0

(c)CURRENT, INC.	SUPER MIX24 CSP350	JAN.2001
H.ICHIIHASHI	PANEL DIAGRAM	CSP350-D

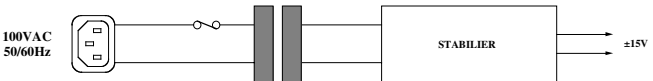
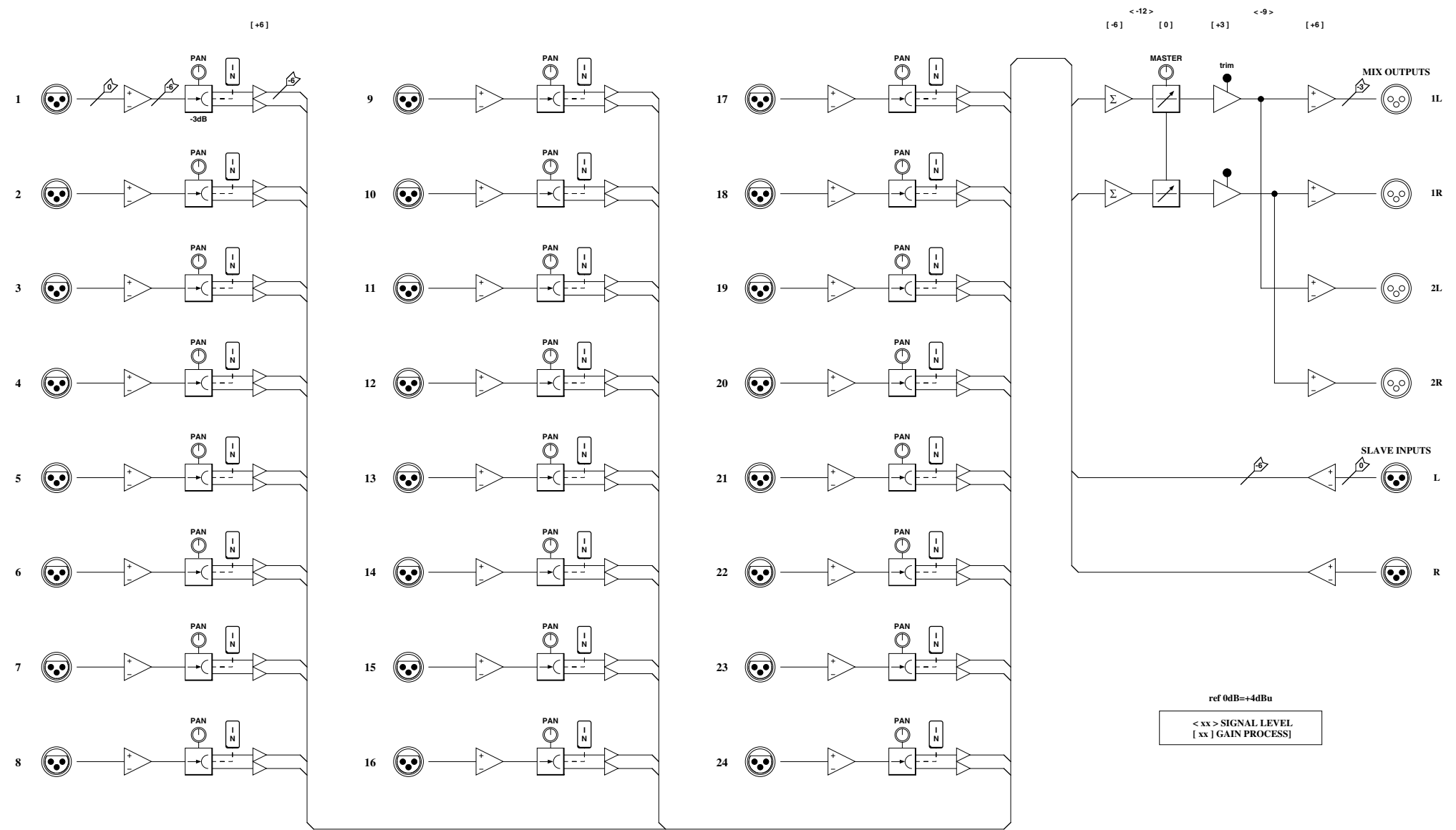

©CURRENT,INC.	CSP350 SUPER MIX	May.2001
H.ICHIHASHI	SYSTEM DIAGRAM	CSP350-B

May.2017