

CURRENT PRODUCTS model:FBMX3

FOLDBACK MIX

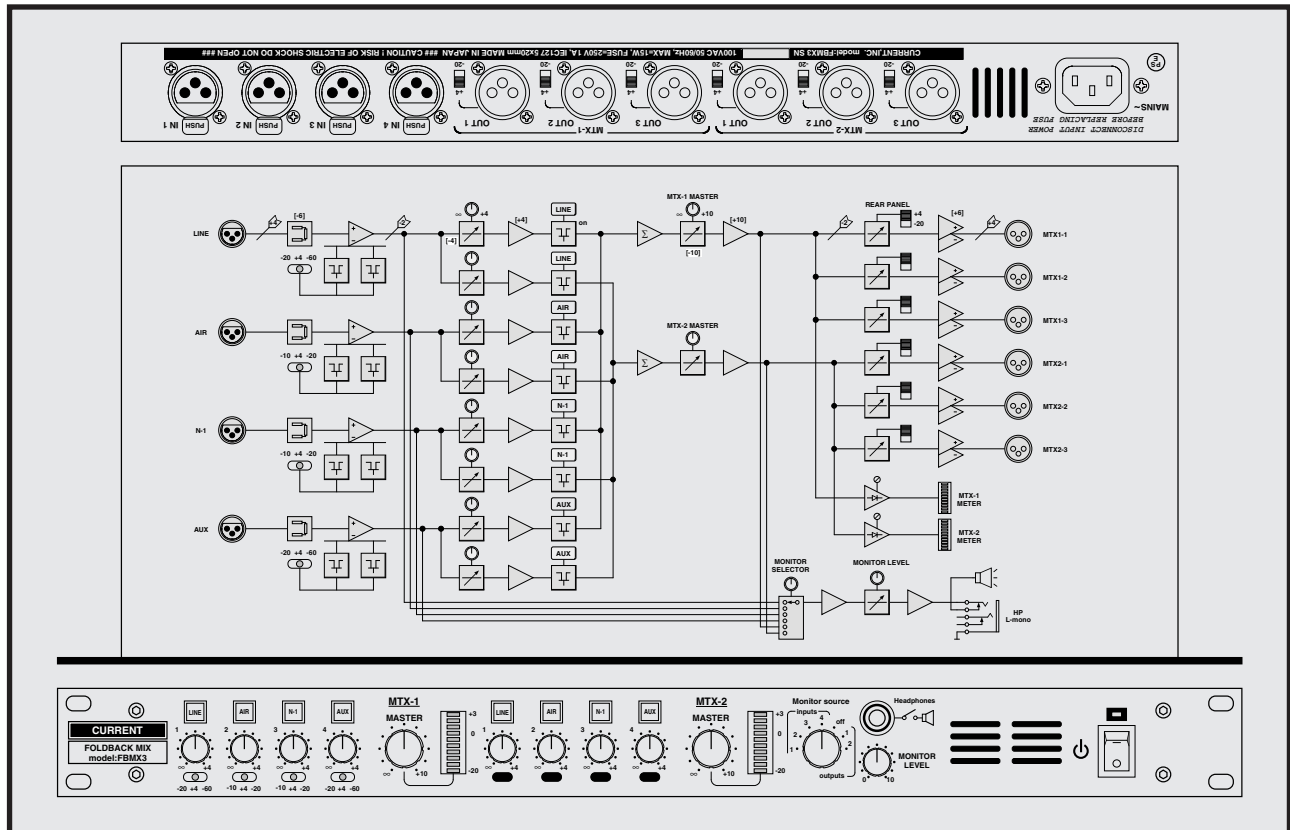

- 4 reference variable input
- 2 routes, for each 3 distribution
- Variable output reference
- Monitor speaker
- Headphone monitor
- Level meter
- 19 inches 1U size

FBMX3 is fold back mixer configured by 4 reference variable input and 2 reference variable output, and, as for the output, 3 distribution is possible each. It is suitable for not only the line but also the microphone level and can use the input for various applications such as talk back system, the audio distributor as microphone / line mixer.

"Input"

As for the reference level of the XLR connector input, 3 stages of setting is possible. 1 and 4 can choose -60, -20, +4dBu, and 2 and 3 can choose -20, -10, +4dBu. It can change the reference level by the designation at the time of the order.

"Routing"

The input signal is sent to the mix amplifier via each mix level and ON button.

"Output"

As for the mix signal, it is output 3 distribution via a reference changeover switch of +4/-20.

"Signal meter"

It can monitor a range of -20dB to +3dB in the bar graph of the VU response with the signal just after the master level.

"Monitoring"

With headphone and a built-in speaker, it switches 4 input and 2 output and can monitor it.

"Power supply"

Please refer about the option of AC power redundancy and the DC12V input.



SPECIFICATIONS

- 🍏 **INPUTS:** 4, BALANCED, 30kΩ
- 🍏 **INPUTS CONNECTOR:** XLR3-F
- 🍏 **INPUTS REFERENCE LEVEL:** -60, -20, -10, +4dBu, MAX +24dBu
- 🍏 **OUTPUTS:** 6 BALANCED, 50Ω
- 🍏 **OUTPUTS REFERENCE LEVEL:** -20, +4dBu, MAX +24dBu
- 🍏 **OUTPUTS CONNECTOR:** XLR3-M
- 🍏 **CONTROL:** CHANNEL LEVEL, CHANNEL ON, MASTER LEVEL
- 🍏 **MONITOR SOURCE:** ALL INPUTS AND OUTPUTS
- 🍏 **HEADPHONES MONITOR:** 1/4" PHONE, MONO IMP. > 50Ω
- 🍏 **MONITOR SPEAKER:** MONO, MAX 500mW
- 🍏 **FREQUENCY RESPONSE:** 20Hz-20kHz ±0.1dB
- 🍏 **THD:** < 0.1% at 1kHz REFERENCE LEVEL
- 🍏 **NOISE:** < -80dB
- 🍏 **MAINS:** 100VAC/+12VDC 50/60Hz 15W(MAX)
- 🍏 **DIMENSIONS:** 482Wx44Hx303D 4kg

Foldback mix	FBMX3	¥640,000
accessory : AC cable		

The specifications are subject to change without notice.
2-26-11 AKATSUTSUMI, SETAGAYA-KU, TOKYO, 156-0044 JAPAN

MONITOR SYSTEM HEADPHONES AMP CUE SYSTEM COMMUNICATION TB COUGH SYSTEM MATRIX AMP AUDIO ROUTER AUDIO VIDEO SWITCHER SYSTEM SWITCHER EMERGENCY AUDIO VIDEO DISTRIBUTOR METER SYSTEM ANALOG, DIGITAL PREAMP MIXER LEVEL UNIT DIGITAL AUDIO FADER UNIT AUTO FADER TALLY FADER CLOCK TIMER EVENT SYSTEM SPECIAL PRODUCTS ETC.

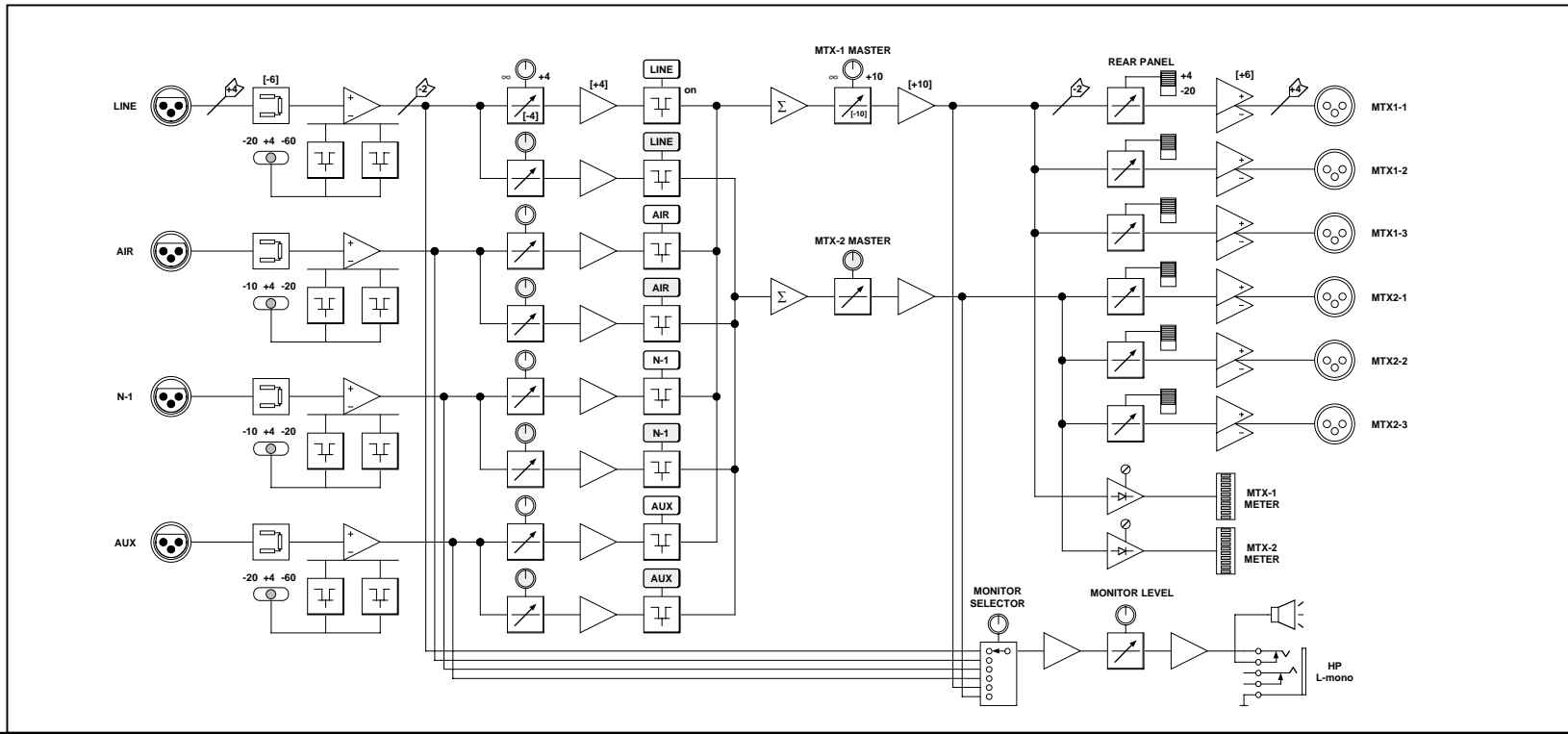
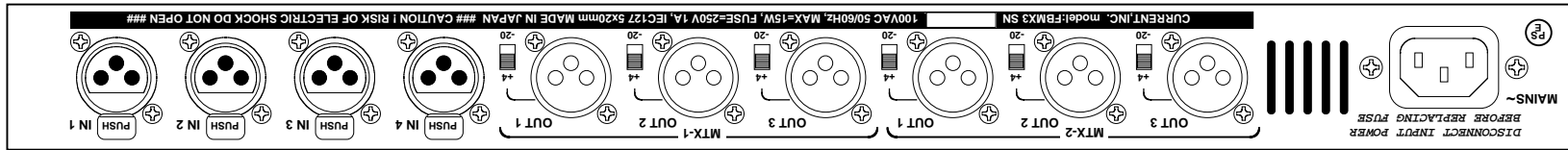

302.6

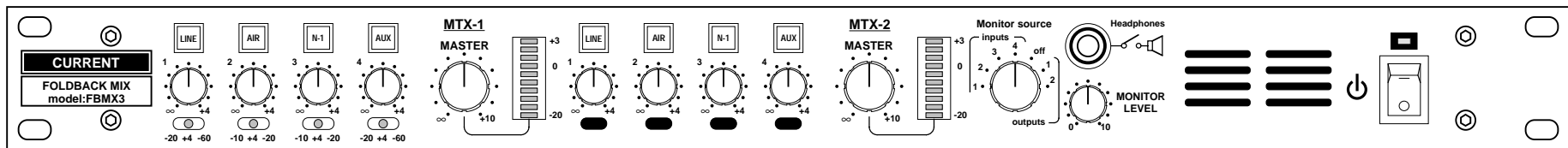

44

482

Oct.2007

(c)CURRENT,INC.	FBMX3 FOLDBACK MIX	Oct.2000
H.ICHIHASHI	PANEL DIAGRAM	FBMX3-D2007