

CURRENT PRODUCTS model:PMS130

30ch MIC AMP

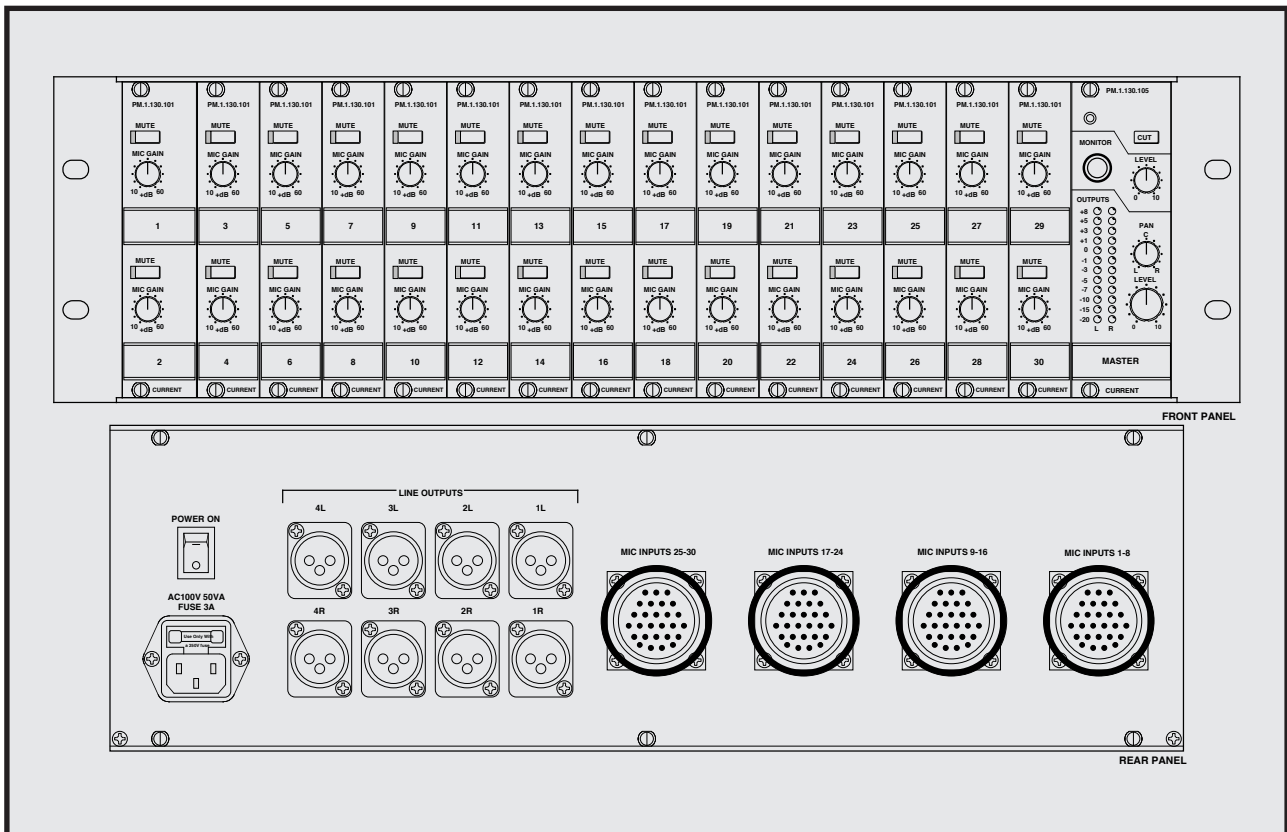

All channel compressor built-in
 It is 30ch at 3 U size
 Modularity
 I/O connector support of every kind
 Headphone monitor

PMS130 is the microphone mixer which up to 30ch can be built in in 19 inches 3U size. Compressor is built in it in all channels and is most suitable for broadcast, the conference room.

"INPUT"

A microphone amplifier of 2ch per 1 input module is equipped with, and microphone trim and CUT switch to each. In addition, compressor is built in it to every microphone amplifier. It can pre-set IN/OUT of the compressor, the setting of the threshold internally.

"MASTER"

A master of the mix level, CUT switch, a headphone monitor are implemented to a master module. The master output is monaural by default. It can change in the stereo output with an odd, an even channel with an option.

"Others"

It can output DIRECT OUT of every microphone amplifier with an option. In addition, please refer about the change of the input and output connector.

SPECIFICATIONS

- 🍏 **MIC INPUTS:** BALANCED, 2k Ω
- 🍏 **MIC TRIM:** +10 ~ +60dB
- 🍏 **CONNECTOR:** USER DEFINED
- 🍏 **LINE OUTPUTS:** BALANCED, 33 Ω
REF=+4dBu, MAX=+24dBu
- 🍏 **FREQUENCY RESPONSE:** 20~20kHz \pm 0.1dB
- 🍏 **THD:** < 0.005% at 1kHz, REF LEVEL
- 🍏 **E.I.N.:** < -128dBu at 60dB gain (20~20kHz)
- 🍏 **HP MONITOR:** >50 Ω MAX=500mW
- 🍏 **MAINS:** 100VAC 50/60Hz, MAX 45W
- 🍏 **DIMENSIONS:** 483Wx132.5Hx350D, 7.5kg

Mic preamp	PMS130	¥1,800,000
accessory : AC cable,		

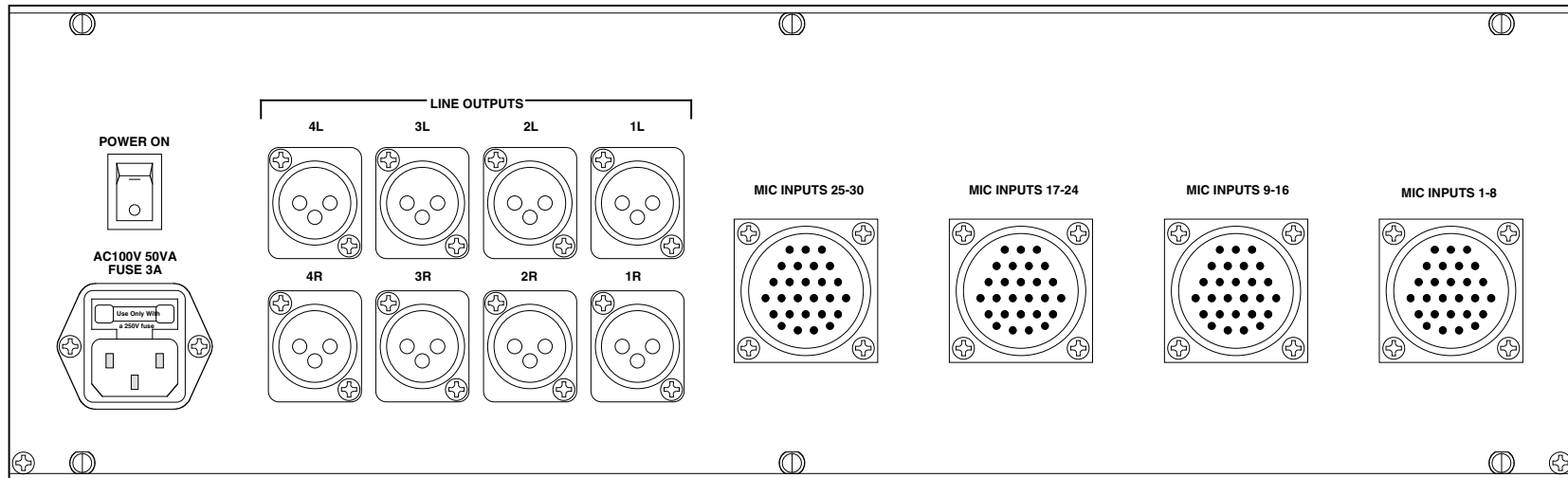

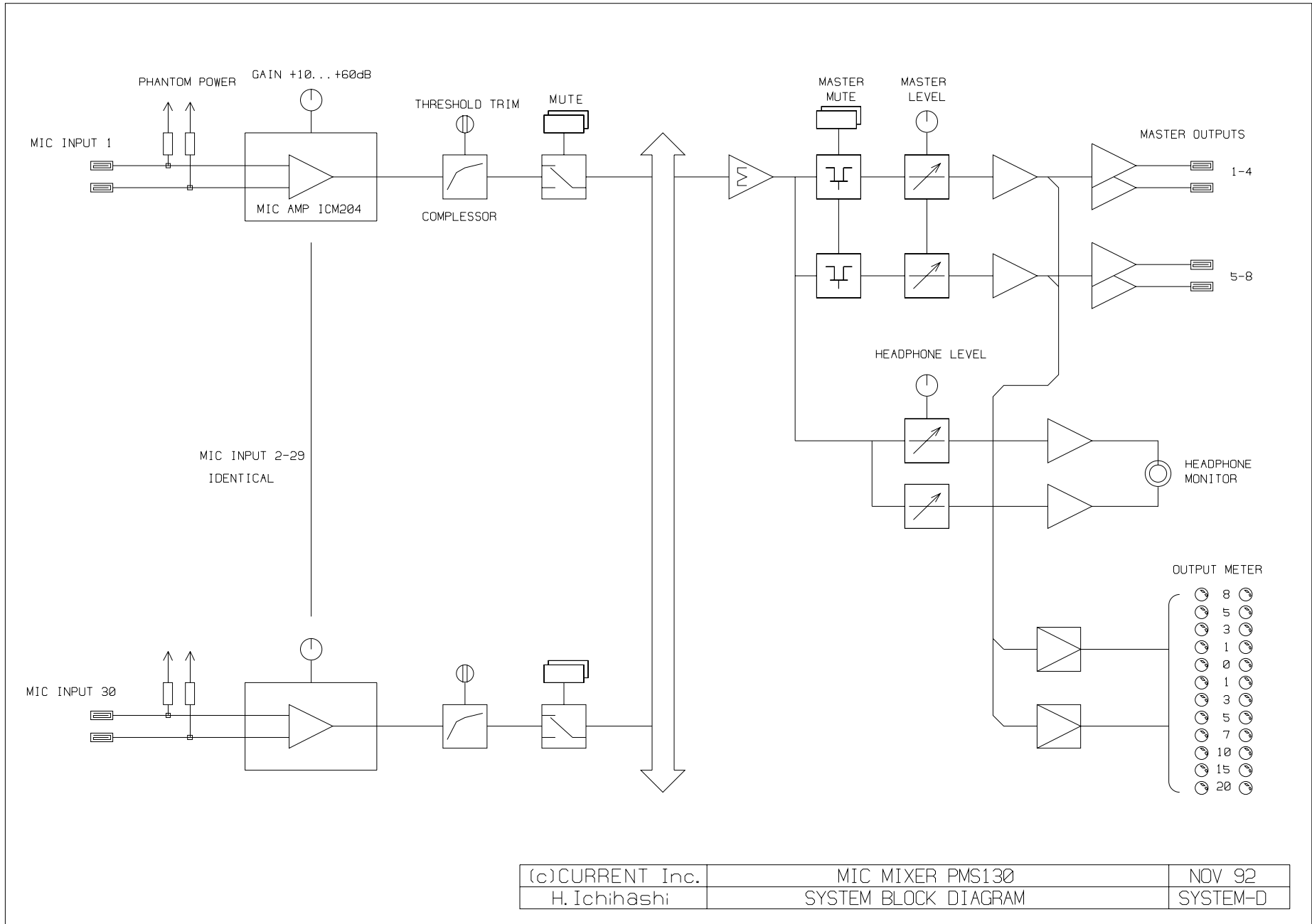

(c)CURRENT Inc. H. Ichihashi	MIC MIXER PMS130 SYSTEM BLOCK DIAGRAM	NOV 92 SYSTEM-D
---------------------------------	--	--------------------